

MagSquare 165 | P/N: 8100494

Welders and fabricators are raving about the versatility, convenience and time savings that come with Magswitch MagSquares. MagSquares are extremely powerful magnetic blocks with strong holding force available on all sides. Precisely position the MagSquare and material, and then turn the magnet on with a quick 180° twist to fixture work pieces at right angles. Unlike manual clamping, no weld tabs or edges are required. Use the pre-tapped holes on each side for attaching the MagSquare to non-ferrous tools, jigs, and fixtures. Just turn the magnet off to remove magnetic dust and debris.



WARNING!

Do Not Operate Unless In Contact With Ferrous Target!

Specifications

Nominal Maximum Breakaway Force ^{1,2}	152.8 lb	69.3 kg
Nominal Maximum Shear Force ^{1,2}	35.3 lb	16.0 kg
Full Saturation Thickness ³	0.197 in	5.0 mm
Side Surface Maximum Breakaway ^{1,2}	93.5 lb	42.4 kg
Net Weight	0.69 lb	0.312 kg
Magnetic Pole Footprint	1.89"x1.23"	48mm x 31.2mm

Material Thickness	0.8	1.0	1.5	2.0	3.0	5.0	12.7
- mm (in)	(0.031)	(0.039)	(0.059)	(0.079)	(0.118)	(0.197)	(0.500)
Maximum Force	10.67	18.20	26.23	36.33	53.53	69.30	69.17
- kg (lbs)	(23.52)	(40.12)	(57.83)	(80.09)	(118.01)	(152.78)	(152.49)

¹ Determined in laboratory environment on SAE1018 Steel with surface roughness 63 micro inches. Many factors contribute to the actual breakaway force and safe working load in each application. Consult a Magswitch Applications Engineer and test the Magswitch in each application before deployment.

² All data applies to unit with flat pole shoes.

³ Determined with SAE1018 Steel L=200mm W=200mm.

⁴ Values may vary by +/- 5%.

⁵ Maximum forces listed above are not safe lifting forces. Designer must take into account safety factor when specifying tool. Magswitch recommends SWL = 5:1 for most applications.





MAGSWITCH MagSquare 165

P/N: 8100494

+ 1(303) 468.0662

magswitch.com

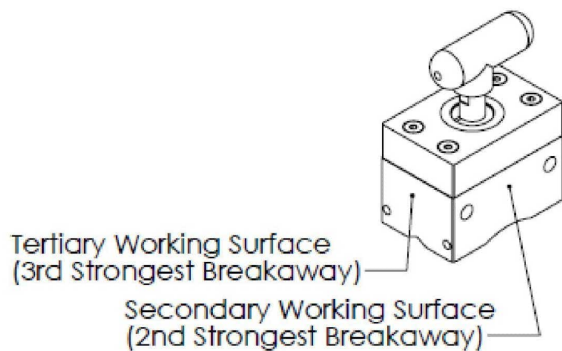
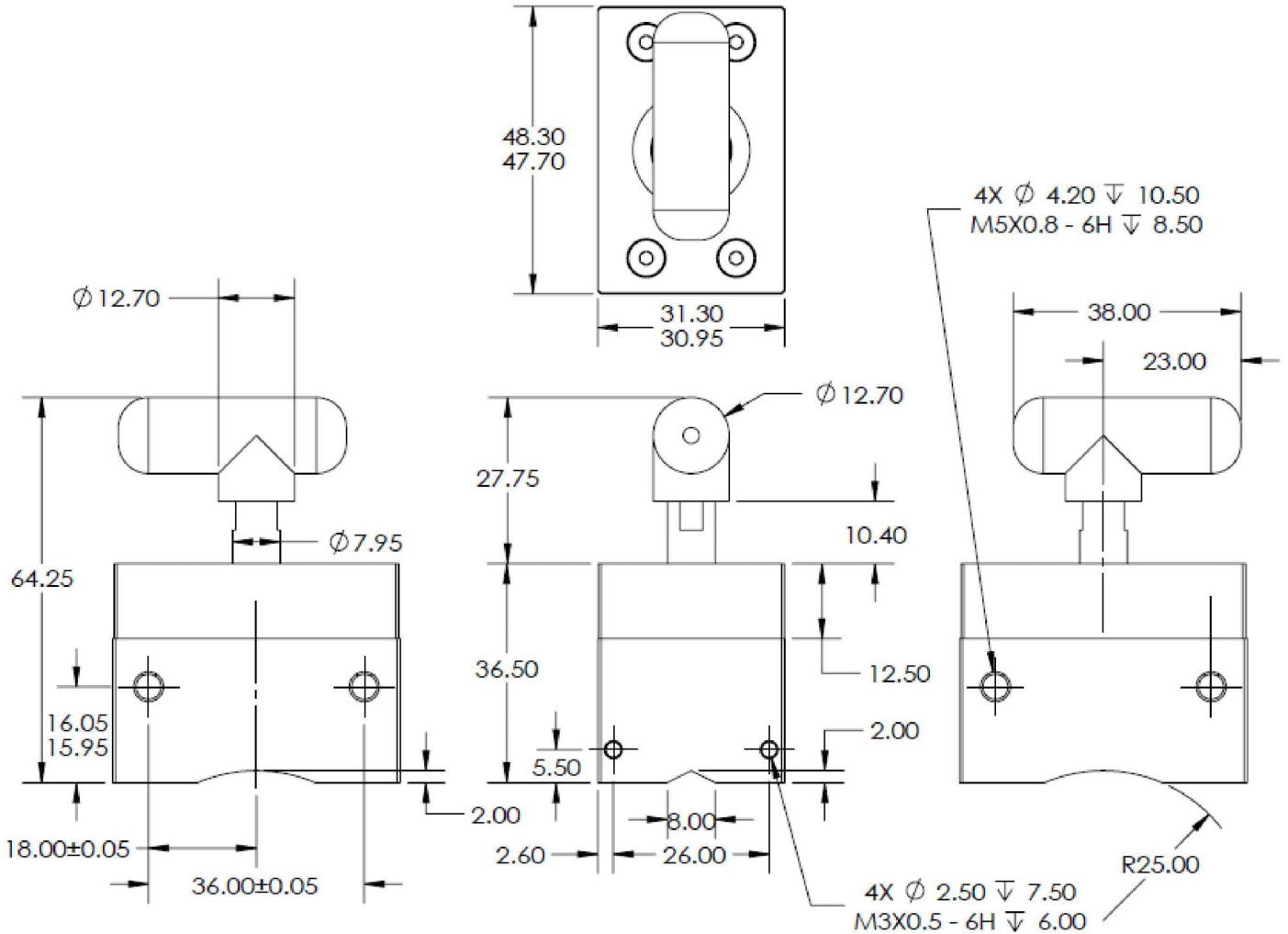

R14.50

BLACK = Primary Working Surface (Strongest Breakaway)

Sales & Service by :



PRECICUT TECHNOLOGIES

Address : S. No. 44/6/1, Pimpale Gurav, New Sangavi, Pune - 411061
Email: fulmaliavinash@gmail.com Mob : 9823048288