



Magswitch Technology, Inc.
1355 Horizon Avenue
Lafayette, CO 80026
Magswitch.com.au
303-468-0662

Magswitch 300 Amp Finned Magnetic Ground Clamp

P/N: 8100746

The Magswitch finned magnetic ground clamps let welders quickly set up, weld and move on to the next job. Simply place it on a clean work surface, turn it on and start welding. Instant ground on a flat surface or a pipe. The finned design lowers the temperature of the unit by almost 27%.

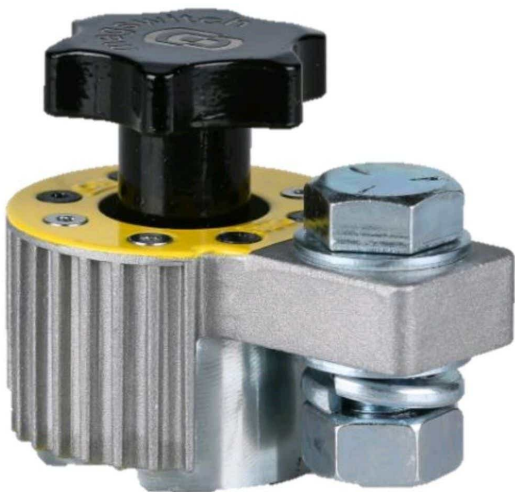

WARNING!
Do Not Operate Unless In Contact With Ferrous Target

SPECIFICATIONS	
P/N: 8100746 - MAGSWITCH 300 Amp Finned Magnetic Ground Clamp	
Magnet Strength	90 lbs/40 kg
Net Weight	0.8 lbs/0.4 kg
Overall Height	57.3 mm
Magnetic Pole Footprint	40mm Diameter

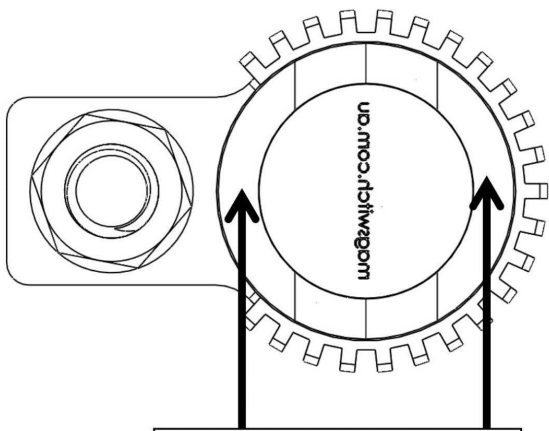

WORKING SURFACE



Part Number 1101142
Revision Date: April 30 2015



PRECICUT TECHNOLOGIES



Part Number 1101142
Revision Date: April 30 2015

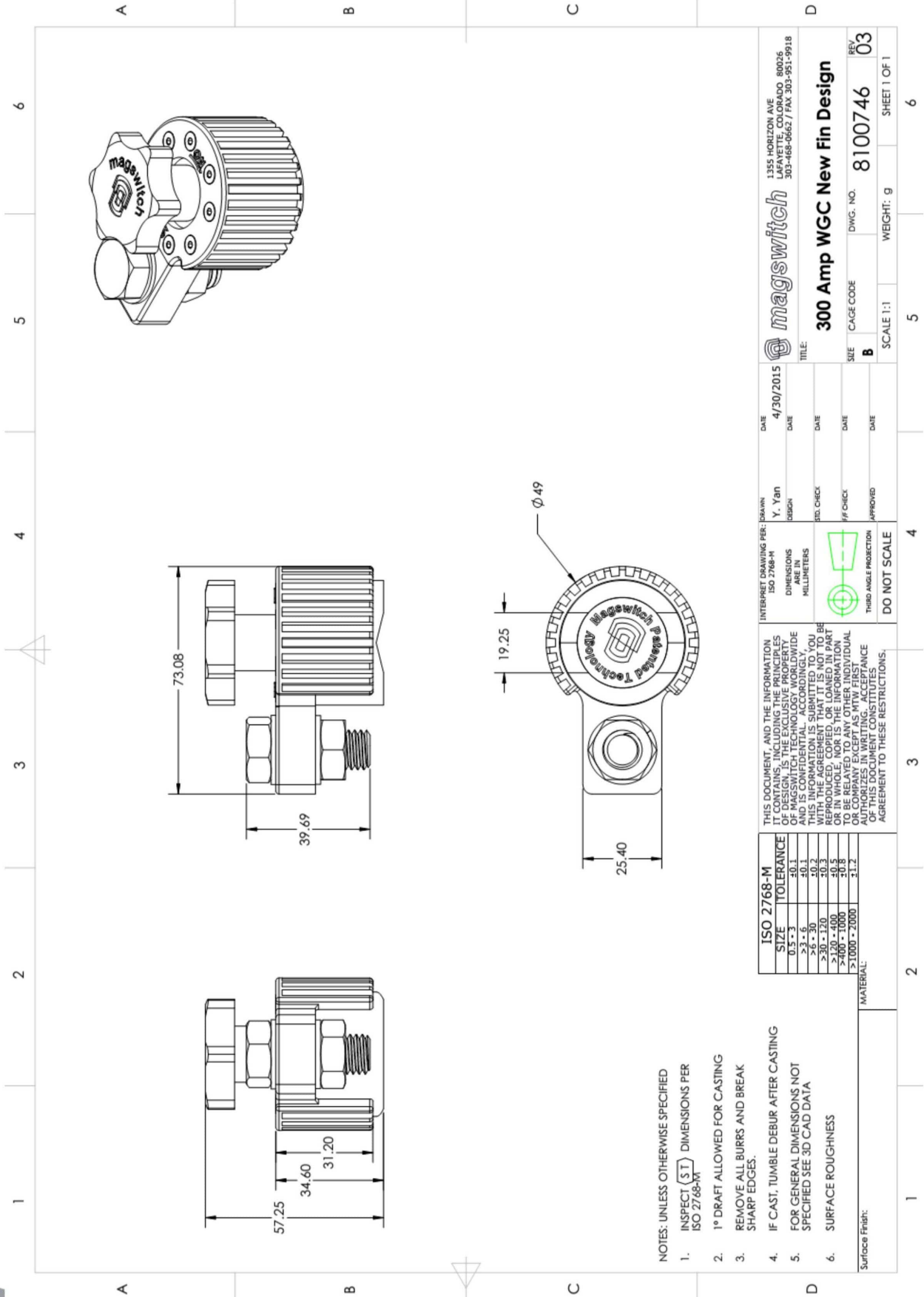

- NOTES: UNLESS OTHERWISE SPECIFIED
- INSPECT (S.T.) DIMENSIONS PER ISO 2768-M
 - 1° DRAFT ALLOWED FOR CASTING
 - REMOVE ALL BURRS AND BREAK SHARP EDGES.
 - IF CAST, TUMBLE DEBUR AFTER CASTING
 - FOR GENERAL DIMENSIONS NOT SPECIFIED SEE 3D CAD DATA
 - SURFACE ROUGHNESS

ISO 2768-M	TOLERANCE
SIZE	
0.5 - 3	±0.1
3 - 6	±0.1
6 - 30	±0.3
30 - 120	±0.5
120 - 400	±0.8
400 - 1000	±1.2
> 1000 - 2000	±1.2

THIS DOCUMENT AND THE INFORMATION IT CONTAINS, INCLUDING THE PRINCIPLES OF DESIGN, IS THE EXCLUSIVE PROPERTY OF MAGSWITCH TECHNOLOGY WORLDWIDE. THIS INFORMATION IS SUBMITTED TO YOU WITH THE AGREEMENT THAT IT IS NOT TO BE REPRODUCED, COPIED, OR LOANED IN PART OR IN WHOLE TO ANY OTHER INDIVIDUAL OR COMPANY EXCEPT AS MTW FIRST AUTHORIZES IN WRITING. ACCEPTANCE OF THIS DOCUMENT CONSTITUTES AGREEMENT TO THESE RESTRICTIONS.

INTERPRET DRAWING PER: DRAWN Y. Yan DESIGN DATE 4/30/2015 ISO 2768-M DIMENSIONS ARE IN MILLIMETERS

3RD CHECK DATE DATE DATE DATE DATE

THIRD ANGLE PROJECTION DO NOT SCALE

magswitch 1355 HORIZON AVE LAFAYETTE, COLORADO 80026 303-468-6662 / FAX: 303-951-9918

TITLE: **300 Amp WGC New Fin Design**

SIZE: B CAGE CODE: DWG. NO. 8100746 REV. 03

SCALE 1:1 WEIGHT: 9 SHEET 1 OF 1



Sales & Service by:

PRECICUT TECHNOLOGIES

Address : S. No. 44/6/1, Pimpale Gurav, New Sangavi, Pune - 411061
Email: fujmaliaivnash@gmail.com Mob : 9823048288